

Automotive Qualified TJ 175°C 100V & 120V Trench Schottky Surface Mount Rectifier

Automotive-qualified TJ 175°C 100V & 120V Trench Schottky Surface Mount Rectifier. With its advanced trench cell design and AEC-Q101 qualification, this rectifier offers unparalleled reliability and performance for automotive applications. Trust in Taiwan Semiconductor for innovative solutions that meet the highest industry standards.



Official Website

X

LinkedIn

For more questions: marketing@ts.com.tw

© 2024 TAIWAN SEMICONDUCTOR, CO., LTD. ALL RIGHTS RESERVED.

PACKAGE

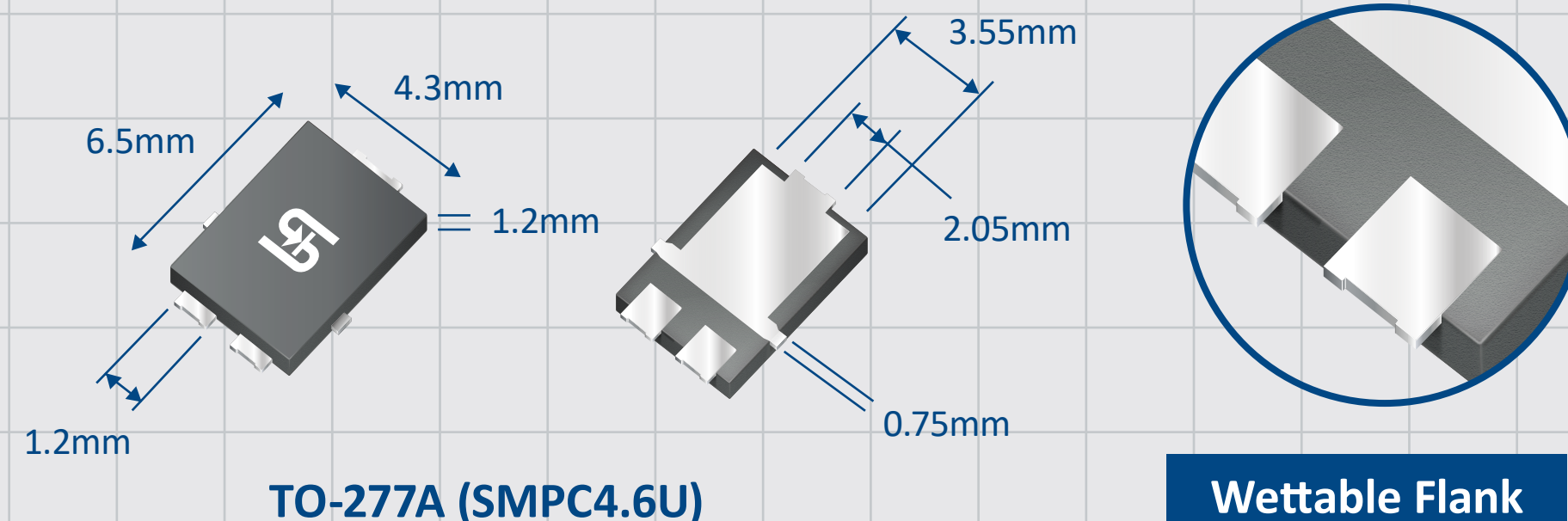

FEATURES



**AUTOMOTIVE
QUALIFIED
AEC-Q101**

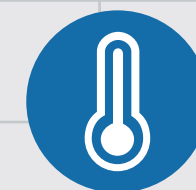

**T_j max, up to
175°C**



**TRENCH SCHOTTKY
TECHNOLOGY**



**LOW POWER LOSS
HIGH EFFICIENCY**

SPECIFICATION

Part number	V _{RRM} (V)	I _F (A)	V _F		I _R @T _A =25°C max.(μA)	I _R @T _A =175°C max.(mA)	I _R @8.3ms (A)	Q _c Typ (nC)
			Typ.(V)	Max.(V)				
TSUP8H100H	100	8	0.71	0.75	50	10	240	583
TSUP10H100H		10	0.71					
TSUP12H100H		12	0.70					
TSUP15H100H		15	0.72					
TSUP8H120H	120	8	0.73	0.76	50	10	240	462
TSUP10H120H		10	0.73					
TSUP12H120H		12	0.72					
TSUP15H120H		15	0.72					

Trench & Planar Schottky V_F Comparison

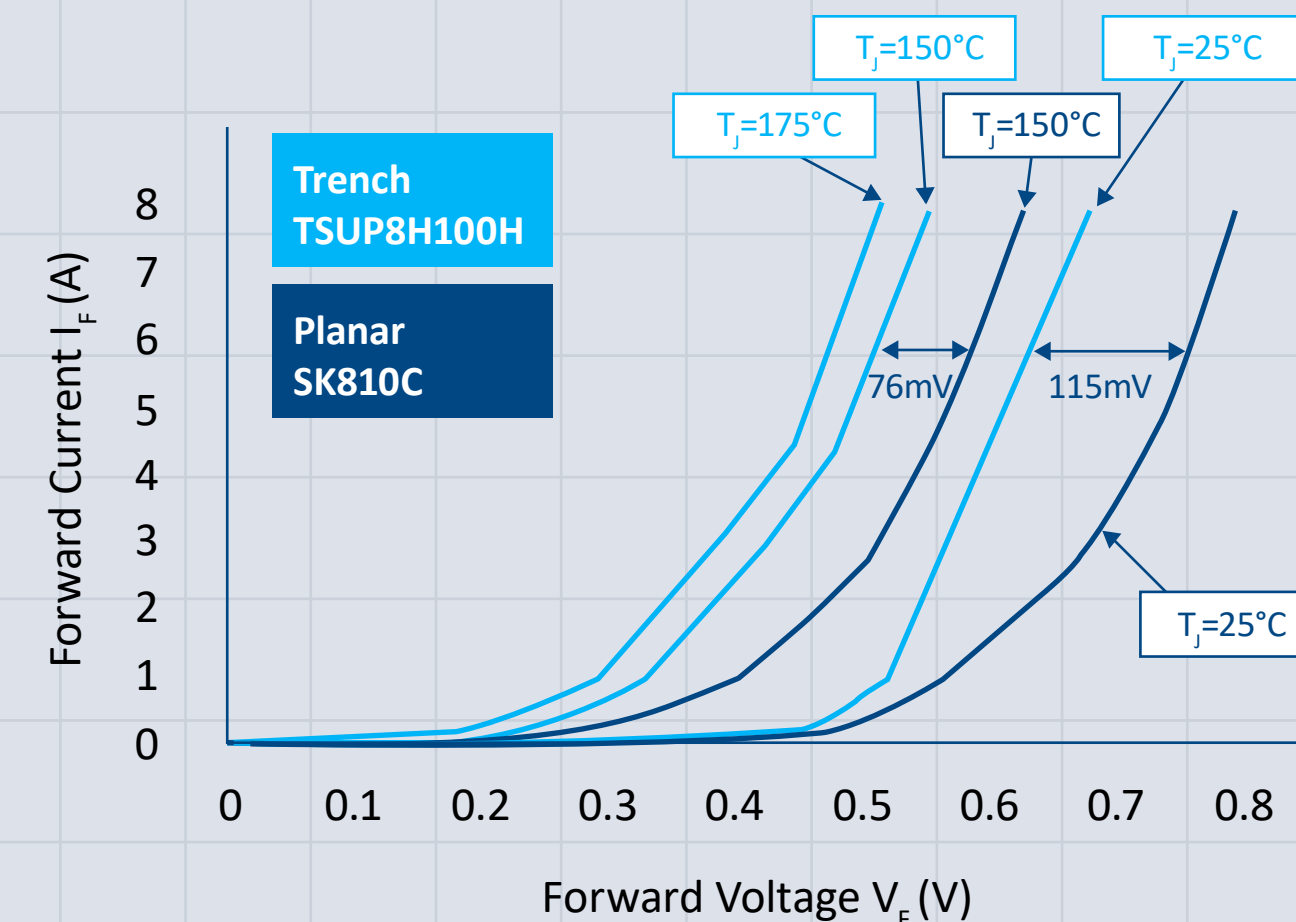

APPLICATIONS



DC/DC
CONVERTER



SMPS



AUTOMOTIVE



LIGHTING



**TAIWAN
SEMICONDUCTOR**

www.taiwansemi.com